



Z121-DR

SPECIFICATION SHEET

12 [305] DIAMETER ROOF DRAIN W/ TOP-SET® DRAIN RISER & LOW SILHOUETTE DOME

TAG _____

Dimensional Data (inches and [mm]) are Subject to Manufacturing Tolerances and Change Without Notice

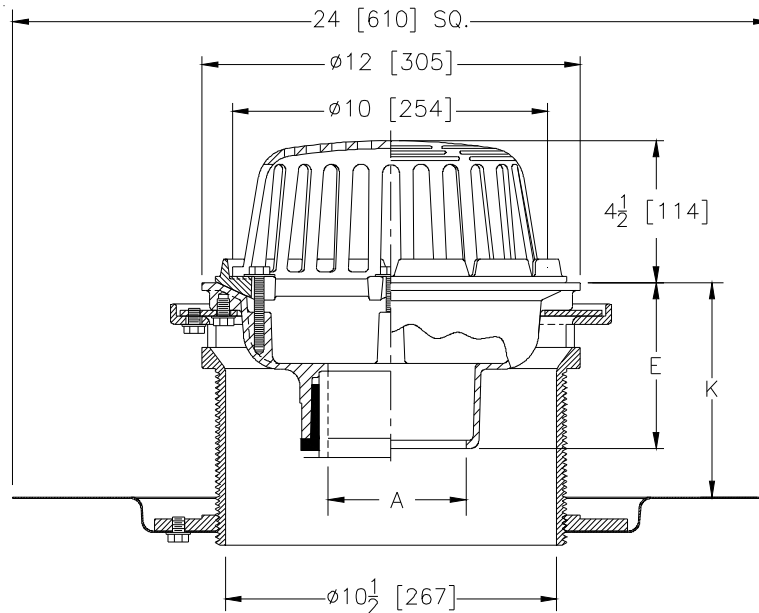

A- Pipe Size In.	K		Approx. Wt. Lbs. [kg]	Dome Open Area Sq. In. [cm ²]
	Min.	Max.		
2-3-4-6 [51-76-102-152]	2-3/4 [69]	6-7/8 [175]	59 [27]	78 [503]

ENGINEERING SPECIFICATION: ZURN Z121-DR
12 [305] Diameter roof drain. Dura-Coated cast iron body with combination membrane flashing clamp/gravel guard, adapter ring, Top-Set® drain riser, drain riser flange, Top-Set® deck plate, and low silhouette Poly-Dome.

OPTIONS (Check/specify appropriate options)

PIPE SIZE

(Specify size/type) **OUTLET**

E BODY HT. DIM.

2,3,4,6 [51,76,102,152]	_____	IC	Inside Caulk	5-1/4 [133]
2,3,4,6 [51,76,102,152]	_____	IP	Threaded	3-3/4 [95]
2,3,4,6 [51,76,102,152]	_____	NH	No-Hub	5-1/4 [133]
2,3,4 [51,76,102]	_____	NL	Neo-Loc	4-5/8 [113]

PREFIXES

- ___ Z D.C.C.I. Body with Poly-Dome (4-1/4 [108] Dome height)*
- ___ ZA D.C.C.I. Body with Aluminum Dome (6-9/16 [167] Dome height)
- ___ ZC D.C.C.I. Body with Cast Iron Dome (4-1/4 [108] Dome height)
- ___ ZRB D.C.C.I. Body with Plain Bronze Dome (3-7/8 [98] Dome height)

SUFFIXES

- ___ -AR Acid Resistant Epoxy Coated
- ___ -BS Bronze Mesh Screen Over Dome
- ___ -DB Deep Sump Body
- ___ -E Static Extension 1 [25] thru 4 [102] (Specify Ht.)
- ___ -FG Flush Grate (Replaces Dome Strainer)
- ___ -G Galvanized Cast Iron
- ___ -SC Secondary Clamping Collar
- ___ -SS Stainless Steel Mesh Screen Over Dome
- ___ -TC Neo-Loc Test Cap Gasket (2-4 [51-102] NL Bottom Outlet Only)
- ___ -VP Vandal Proof Secured Top
- ___ -XJ Vertical Expansion Joint (See Z190)
- ___ -84 Stainless Steel Perforated Gravel Guard
- ___ -85 Stainless Steel Perforated Extension
- ___ -89 2 [51] High External Water Dam

*REGULARLY FURNISHED UNLESS OTHERWISE SPECIFIED

REV. C	DATE: 12/11/12	C.N. NO. 128578
DWG. NO. 67595	PRODUCT NO. Z121-DR	

ZURN INDUSTRIES, LLC. ♦ SPECIFICATION DRAINAGE OPERATION ♦ 1801 Pittsburgh Ave. ♦ Erie, PA 16514

Phone: 814/455-0921 ♦ Fax: 814/454-7929 ♦ World Wide Web: www.zurn.com

In Canada: ZURN INDUSTRIES LIMITED ♦ 3544 Nashua Drive ♦ Mississauga, Ontario L4V1L2 ♦ Phone: 905/405-8272 Fax: 905/405-1292